

STIEBEL ELTRON

Simply the Best

Indirect & Solar Storage Tanks for Domestic Hot Water

New!
Single coil tanks
with electric element

Tanks being porcelain-fired at Stiebel Eltron's factory in Holzminden, Germany

DHW Tanks

FOR ALL SOLAR, GEOTHERMAL
OR HYDRONIC APPLICATIONS



ISO 9001
CERTIFIED



- › Heavy Gauge Steel With Porcelain Enamel Coating
- › Superb Quality Results In Long Service Life Backed By A Lifetime Warranty
- › Sacrificial Anode Rod
- › Up To 3" R-21 Urethane Foam Insulation For Low Standby Heat Loss
- › Large Clean-Out Port For Ease Of Maintenance

800.582.8423

www.stiebel-eltron-usa.com

New! SB-E Tanks

- › Solar-ready
- › Powder-coated steel outer jacket
- › Standard junction box for electrical connection
- › ALL connections are NPT
- › Two auxiliary ports
- › Sleeved heating element can be replaced without draining tank

Single Heat Exchanger with Electric Element

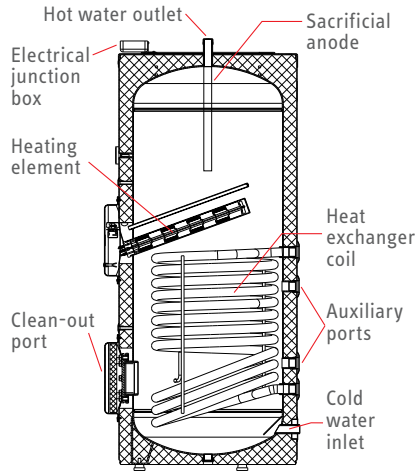

Intertek

Conforms to ANSI/UL Std. 174. Certified to CAN/CSA Std. C22.2 No. 110-94.



Stiebel Eltron SBB and SB-E tanks and heat exchangers are warranted against material defects for 10 years, excluding the sacrificial anode. See warranty for complete details.



Tested and Certified by Water Quality Association against NSF/ANSI 372 for lead free compliance.

DHW Tank Model	SB 300 E	SB 400 E
Part number	234110	234111
CONTENTS		
Storage capacity	79.3 gal (300 l)	105.6 gal (400 l)
Heat exchanger volume	2.4 gal (9.5 l)	2.9 gal (11.1 l)
Surface area of heat exchanger	16.1 ft ² (1.5 m ²)	20.6 ft ² (1.9 m ²)
Working pressure	145 psi (10 bar)	
Max. pressure of boiler loop	145 psi (10 bar)	
HEATING ELEMENT		
Heating element voltage	220 - 240 V, 60 Hz	
Heating capacity	10,239 Btu/hr (3.0 kW)	
Rated current	12.5 A	
Required circuit breaker	20 A	
Heating element	Ceramic dome element	
Temperature control	Knob with °F & °C scale under heating element cover	
Set range of thermostat	86 - 167 °F (30 - 75 °C)	
OTHER		
Cold/hot water connection	1" male NPT	
Heat exchanger & auxiliary connections	1" female NPT	
PERFORMANCE DATA		
Standby losses in 24 hours	2.8 kW (9,553 Btu)	3.0 kW (10,236 Btu)
Pressure drop at 4.4 gpm	3.7 ft. head (11 kPa)	4.0 ft. head (12 kPa)
Heat exchanger power rating Inlet 50°F, 140°F Outlet	165,000 Btu/hr (48.4 kW)	183,000 Btu/hr (53.7 kW)
Recovery rate (maximum input)	234 gal/hr (885 l/hr)	258 gal/hr (976 l/hr)
Recovery rate (electric element only)	13.7 gal/hr (51.8 l/hr)	13.7 gal/hr (51.8 l/hr)
WEIGHTS & DIMENSIONS		
Tank weight empty	355 lb (161 kg)	432 lb (196 kg)
Tank weight full	1,051 lb (477 kg)	1,366 lb (169 kg)
Height	61 1/8" (1552 mm)	60 13/16" (1544 mm)
Diameter	25 9/16" (650 mm)	29 1/2" (750 mm)
Insulation thickness	2" (50 mm)	
Diameter without insulation	21 5/8" (550 mm)	25 9/16" (650 mm)

- 1 Cold water inlet
- 2 Hot water outlet
- 3 Lower heat exchanger port
- 4 Upper heat exchanger port
- 5 Lower auxiliary port
- 6 Upper auxiliary port
- 7 Clean-out port
- 8 T&P valve port
- 9 Anode replacement indicator
- 10 Junction box
- 11 Analog thermometer
- 12 Upper temperature sensor sleeve
- 13 Electric heating element
- 14 Lower temperature sensor sleeve

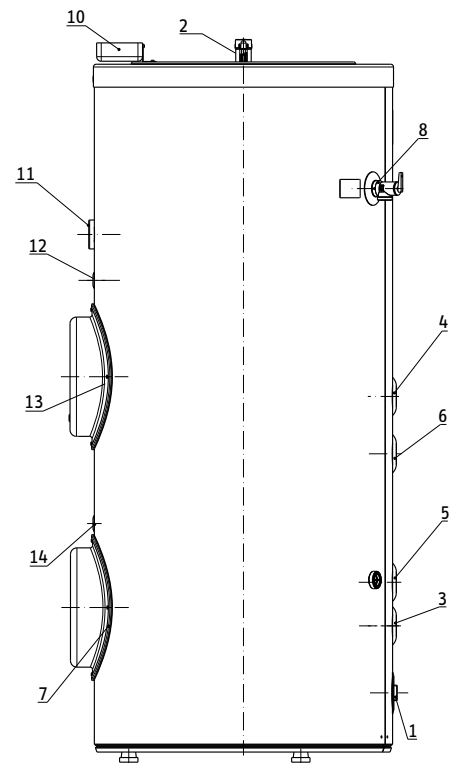

Highly Efficient Domestic Hot Water Storage Tanks for Solar Thermal, Geothermal or Hydronic Applications

Single Heat Exchanger



SBB 400 S

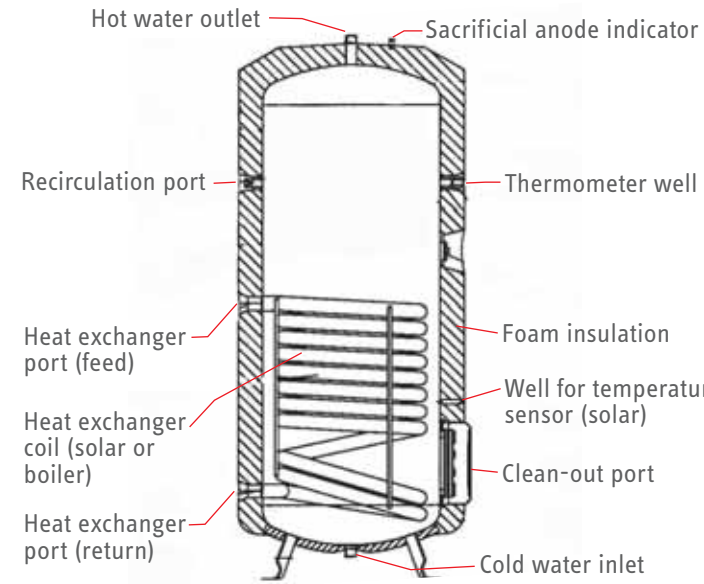

DHW Tank Model	SBB 400 S
Part number	221222
CONTENTS	
Storage capacity	108.6 gal (411 l)
Upper heat exchanger volume	NA
Lower heat exchanger volume	3.0 gal (11.3 l)
PRESSURE	
Working pressure	150 psi (10 bar)
Tested to pressure	217 psi (15 bar)
Max. pressure of boiler loop	1150 psi (10 bar)
TEMPERATURE	
Max. temp. upper loop	NA
Max. temp. lower loop	266 °F (130 °C)
HEAT EXCHANGER	
Surface area of heat exchanger, upper	NA
Surface area of heat exchanger, lower	2635 in ² (1.7 m ²)
WEIGHTS & DIMENSIONS	
Tank weight empty	371 lb (169 kg)
Tank weight full	1304 lb (591 kg)
Height with insulation	72 3/4" (1848 mm)
Width with insulation	29 1/2" (750 mm)
Thickness of insulation	3" (75 mm)
OTHER	
Cold/hot water connection	1" male BSPP, with sweat adaptor to 1" copper pipe
PERFORMANCE DATA	
Standby losses in 24 hours	7500 Btu (2.2 kWh)
Continuous Draw (Lower Coil) ¹	
Flow Rate	312 gal/hr (1,181 l/hr)
Output	164,049 Btu (48 kW)

SBB 300 Plus, SBB 400 Plus, SBB 600 Plus

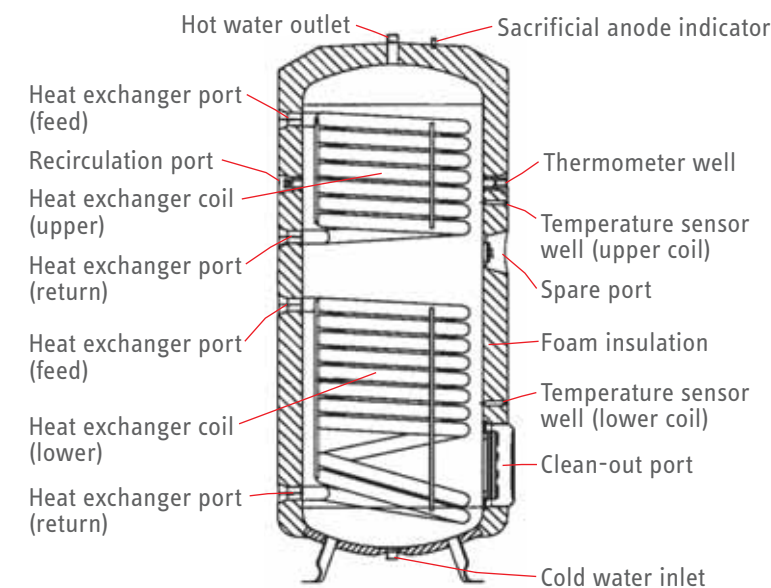

Dual Heat Exchanger



DHW Tank Model	SBB 300 Plus	SBB 400 Plus	SBB 600 Plus
Part number	187873	187874	187875
CONTENTS			
Storage capacity	80.6 gal (305 l)	108.6 gal (411 l)	162.9 gal (617 l)
Upper heat exchanger volume	1.9 gal (7.3 l)	2.2 gal (8.2 l)	2.5 gal (9.6 l)
Lower heat exchanger volume	2.7 gal (10.2 l)	3.0 gal (11.3 l)	3.5 gal (13.2 l)
PRESSURE			
Working pressure	150 psi (10 bar)	150 psi (10 bar)	150 psi (10 bar)
Tested to pressure	217 psi (15 bar)	217 psi (15 bar)	217 psi (15 bar)
Max. pressure of boiler loop	150 psi (10 bar)	150 psi (10 bar)	150 psi (10 bar)
TEMPERATURE			
Max. temp. upper loop	266 °F (130 °C)	266 °F (130 °C)	266 °F (130 °C)
Max. temp. lower loop	266 °F (130 °C)	266 °F (130 °C)	266 °F (130 °C)
HEAT EXCHANGER			
Surface area of heat exchanger, upper	1705 in ² (1.1 m ²)	2015 in ² (1.3 m ²)	2945 in ² (1.9 m ²)
Surface area of heat exchanger, lower	2325 in ² (1.5 m ²)	2635 in ² (1.7 m ²)	3875 in ² (2.5 m ²)
WEIGHTS & DIMENSIONS			
Tank weight empty	339 lb (154 kg)	412 lb (187 kg)	544 lb (247 kg)
Tank weight full	1051 lb (477 kg)	1362 lb (618 kg)	1955 lb (887 kg)
Height with insulation	66 1/8" (1679 mm)	72 3/4" (1848 mm)	68 5/16" (1735 mm)
Width with insulation	27 9/16" (700 mm)	29 1/2" (750 mm)	36 1/4" (920 mm)
Thickness of insulation	3" (75 mm)	3" (75 mm)	3 3/8" (85 mm)
OTHER			
Cold/hot water connection	1" male BSPP, with sweat adaptor to 1" copper pipe		
HX/Aux. connections	1" female male BSPP, with sweat adaptor to 1" copper pipe		
PERFORMANCE DATA			
Standby losses in 24 hours	6500 Btu (1.9 kWh)	7500 Btu (2.2 kWh)	10000 Btu (2.9 kWh)
Continuous Draw (Upper Coil) ¹			
Flow Rate	212.4 gal/hr (804 l/hr)	244.9 gal/hr (927 l/hr)	346.9 gal/hr / 1,313 l/hr
Output	111,680 Btu (33 kW)	128,768 Btu (37.7 kW)	182,399 Btu (53.5 kW)
Continuous Draw (Lower Coil) ¹			
Flow Rate	285.6 gal/hr (1,081 l/hr)	312 gal/hr (1,181 l/hr)	461 gal/hr (1,745 l/hr)
Output	150,168 Btu (44 kW)	164,049 Btu (48 kW)	242,393 Btu (71 kW)

¹ Continuous draw data based on 167 °F (75 °C) heat input / 113 °F (45 °C) DHW output / 50 °F (10 °C) cold water input
² Insulation is partially removable to reduce width to 31 1/2" (800 mm) for clearance purposes



Stiebel Eltron SBB and SB-E tanks and heat exchangers are warranted against material defects for 10 years, excluding the sacrificial anode. See warranty for complete details.

Engineering & Manufacturing Excellence Over 90 Years Of German Technology

All Stiebel Eltron SBB/SB-E series tanks are made in our factories in Germany and Slovakia. They can be used in residential or commercial installations as indirectly-fired domestic hot water storage tanks in conjunction with any type of boiler, geothermal, or solar hot water application.



Tanks being porcelain-fired at Stiebel Eltron's factory in Holzminden, Germany

The vessels and heat exchangers in SBB/SB-E tanks are made from heavy gauge steel. All surfaces in contact with domestic hot water receive a thick porcelain enamel coating after shot-peening to clean the steel surface. In addition, vessel exteriors receive a light porcelain coating. Up to three inches of urethane foam insulation ensures that hot water stays hot, and standby heat loss is minimized. All SBB/SB-E tanks come with heavy-duty sacrificial anodes and visible anode wear indicators. SBB/SB-E tanks are also fitted with an extra-large clean-out port for ease of maintenance.

Stiebel Eltron SBB series tanks are equipped with either one or two large-bore heat exchangers, designed to maximize heat transfer. For solar thermal applications, an SBB tank can be used with an external backup heater, or an SB-E tank with its integral electric element can be used. Dual heat exchanger models are typically used in solar thermal applications by connecting the lower coil to the collector array, and the upper coil connected to any type of boiler for backup heat input or as a takeoff for a radiant heating loop.



SBB tanks are ETL certified in US & Canada to IAS U.S. Requirements for Indirect Fired Water Heaters For Use With External Heat Source. No 1-91, Dated June 6, 1992



Tested and Certified by Water Quality Association against NSF/ANSI 372 for lead free compliance.

1924

Sometimes a "little thing" leads to a whole lot more

Dr. Theodor Stiebel designed the first coil immersion heater and founded "ELTRON Dr. Theodor Stiebel" in 1924 in a small workshop on Reichenberger Strasse in Berlin, Germany.

Since then, Stiebel Eltron has manufactured 20 million tankless electric water heaters, holds hundreds of patents, has won more than fifty design awards, and continues to stay at the forefront of water heating technology.



2019

Continuing to lead innovation in energy efficiency

One of the first manufacturers to develop and manufacture heat pumps and solar thermal water heating, Stiebel Eltron has been a technological leader in renewable energy since 1976.

Today Stiebel Eltron is the heat pump market leader in Germany, and continues creating innovative, energy efficient products for the homes of the future.

Stiebel Eltron Family of Energy Saving Water Heating Products



Efficient tankless electric water heaters

TANKLESS HOT WATER



Point-of-use Tankless



Whole House Tankless



Stiebel Eltron's plant in Holzminden, Germany.

Stiebel Eltron has been a world leader in the development of advanced water heating technology for more than 90 years. Our pursuit of engineering excellence and high-quality manufacturing results in products fulfilling the highest expectations of performance and reliability. They are...**Simply the Best.**

RENEWABLE ENERGY



Complete Solar Hot Water Components



Heat Pump Water Heaters



Solar Thermal & Heat Pump Water Heaters

Distributed by: